

Essential oil compositions of *in vitro* callus culture of ten populations *Hypericum scabrum* L. from Turkey

Ömer Kiliç¹, Fethi Ahmet Özdemir²

¹Department of Park and Garden Plants, Technical Science Vocational College, Bingol University, Bingol, Turkey - E-mail: omerkilic77@gmail.com; ²Department of Molecular Biology and Genetics, Faculty of Science and Art, Bingol University, Bingol, Turkey

Summary. This study aims to develop *in vitro* callus from hypocotyl explants of ten different wild populations of *H. scabrum* growing in Turkey and evaluate the potential of these callus essential oils production with industrial application. Hypocotyl parts of *in vitro* growing plants used as explants sources. *In vitro* cultures were established on MS medium supplemented with 2 mg/L 2,4-D + 0.1 mg/L BAP. Some *Hypericum* taxa callus contains naphthodianthrones, phloroglucinols, tannins, xanthenes, phenolic acids and essential oil. According to the HS-SPME/GC-MS analyses, a total of forty-one components were detected in ten *H. scabrum* calli with relatively high variation in their essential oil composition. Among constituents, α -pinene (7.68-40.20%), β -pinene (1.30-35.74%), limonene (0.02-32.21%), β -ocimene (0.0-37.90%) and germacrene D (0.15-30.55%) were found as the most abundant constituents in studied populations calli essential oils. Results showed that *in vitro* calli could be a good experimental system for further researches on essential oil production.

Key words: callus culture, essential oil, *Hypericum scabrum*

Introduction

The genus *Hypericum* L. is the largest member of the Hypericaceae family, now usually included as subfamily (Hypericoideae) in Clusiaceae (Guttiferae) and comprises more than 470 species divided in 36 sections with worldwide distribution in warm temperate, subtropical and mountainous tropical regions (1). This genus is represented by nearly 100 taxa grouped under 19 sections in Turkey, among them, 45 taxa are endemic. In the traditional medicine of Turkey, the genus is known as “sarı kantaron, kantaron, binbirdelik otu, mayasil otu” and most of them, have been used for the treatment of burns, wounds, haemorrhoids, diarrhoea, ulcers and psychological diseases such as neuralgia, anxiety, neurosis and depression (2-5). Moreover *Hypericum* taxa have been used in the traditional medicine for centuries and many of them have great economic importance as natural sources of active compounds

(6). Nowadays, biological activity of different *Hypericum* species have been investigated and documented in number of studies (7-9). Morphologically, *Hypericum* is characterized by the presence of different types of secretory structures including translucent glands, black nodules and secretory canals. Essential oils are synthesized either in translucent glands or in secretory canals that may be localized in leaves, petals, sepals and pistil (10). Monographs for the crude drug, extracts of which are prepared from the aerial flowering portions of the plant, have been included in the European Pharmacopoeia (11). An infused oil of the flowers, which is prepared by macerating fresh flowers in olive or sunflower oil and exposing the mixture to sunlight for two to three weeks, has a history of traditional use in Europe for treatment of burns and ulcers (12). Oleum hyperici has a red color when either fresh flowers are extracted or heat is applied during the maceration process, although the naphthodianthrones (specifically hypericin

and pseudohypericin) are not extracted into the oil. It has been proposed that a related emodin-derivative(s), specifically a degradation product of hypericin upon exposure to sunlight, is responsible for this coloration, but these have not yet been isolated (13,14).

Recently, there has been increasing interest in the genus *Hypericum*, because it is a source of a variety of chemical compounds (15). Modern studies have been focused on the activity of extracts of these plants against certain viruses and bacteria and on their possible applications as medicines for various diseases (16). Many reports have been published for antimicrobial, antifungal, antiviral, antioxidant, antidepressant and anticonvulsant activities of *Hypericum* taxa (17). Previous reports showed that *H. scabrum* L. has antimicrobial, sedative effect, antiseptic, antidiarrhea, antihemorrhoid, antieczema, antipsoriasis, anthelmintic, antifungal and antiulcerogenic activities (18, 19). According to the phytochemical studies on *H. scabrum*, it has been reported that the essential oil constituents belong to different chemical classes with a considerable qualitative and quantitative variation in composition (20, 21). This variability could be related to the effect of variables such as genetic factors, developmental stages, types of plant materials, methods of extraction, environmental conditions, etc. Although, there are some comparative studies on the essential oil constituents of *H. scabrum* (20), to the best of our knowledge this is the first record on *in vitro* callus induced and these calli essential oil in Turkey populations. Therefore, the present study is investigate *in vitro* callus propagation and evaluate these calli essential oil from ten different wild populations of *H. scabrum* plants collected from Turkey. This study the first report on the essential oils of callus culture of *H. scabrum*.

Material and Methods

Plant material source

The seeds of ten taxa *Hypericum scabrum* collected from Yozgat: Akdağ Madeni, Ankara to Sivas, vicinity of Davutlu village, steppe, rocky and stony place, opening of *Quercus* foresty, 1150-1250 m, 18.06.2014, Kılıç 5424. Bingöl: Vicinity of Dikme village, rocky areas, 1650-1700 m., 18.06.2013, Kılıç 5286. Elazığ: Keban, north of Aslankaşı village,

rocky slopes, 1300-1400 m., 25.06.2013, Kılıç 5327. Malatya: Malatya to Elazığ, exit of Sürgü, road edges, 1300-1350 m, 05.07.2015, Kılıç 5689. Sivas: Zara, between Halkalı and Korkut villages, steppe, gypsum areas, hill, slope, rocky and stony place opening of foresty, 1400-1500 m, 19.06.2014, Kılıç 5426. Tunceli: Ovacık, Munzur mountains, Yılanlı mountain, rocky and stony place, 1800-2000 m, 12.06.2015, Kılıç 5684. şanlıurfa: Between Siverek to şanlıurfa, 20. km, road edge, rocky areas, 600-700 m, 07.06.2014, Kılıç 5415. Adıyaman: Between Turuş village and Atatürk Dam, rocky-steppe areas, 600-700 m, 08.06.2014, Kılıç 5417. Bitlis: Tatvan, vicinity of Suboyu village, rocky and stony slopes, 1650-1750 m, 27.06.2015, Kılıç 5687. Muş: Muş-Bingöl 10. km roadside, steppe, 1300-1350 m, 28.06.2015, Kılıç 5688. Plant materials were identified with Flora of Turkey and East Aegean Islands (22). Voucher specimens were deposited in the Department of Park and Garden Plants of Technical Vocational College / Bingöl University.

Callus culture

The seeds of ten taxa *Hypericum scabrum* were treated with 100% commercial bleach (5% NaOCl Ace, Turkey) for 20 min. followed by 3 × 3 min. rinsing with sterilized distilled water. These were cultured on agar solidified MS medium (23) contained in Petri dishes (100 ×10 mm) supplemented with 3% sucrose to sprout them under 16 h light photoperiod (35 $\mu\text{mol m}^{-2}\text{s}^{-1}$) in Aralab versatile growth chamber at 24 ± 1 C. Hypocotyl explants were obtained from 14 days old young seedlings. Hypocotyl explants were cultured on MS medium containing 2 mg/l 2,4-D plus 0.1 mg/l BAP supplemented with 3% (w/v) sucrose and 0.65% (w/v) plant agar (Duchefa). All media were autoclaved for 20 min. at 121°C and 1.4 kg cm^{-2} pressure. The pH of all media was adjusted to 5.7 ± 0.1 with 1N NaOH or 1N HCl. Each treatment contained 30 explants that were divided into three equally distributed replications.

HS-SPME procedure

Five grams powder each of callus samples were carried out by a (HS-SPME) head space solid phase

microextraction method using a divinyl benzene/carbon/polydimethylsiloxane (DVB/CAR/PDMS) fiber, with 50/30 μm film thickness; before the analysis the fiber was pre conditioned in the injection port of the gas chromatography (GC) as indicated by the manufacturer. For each sample, 5 g of callus samples, previously homogenized, were weighed in to a 40 ml vial; the vial was equipped with a "mininert" valve. The vial was kept at 35°C with continuous internal stirring and the sample was left to equilibrate for 30 min; then, the SPME fiber was exposed for 40 min to the headspace while maintaining the sample at 35°C. After sampling, the SPME fiber was introduced into the GC injector, and was left for 3 min to allow the analyses thermal desorption. In order to optimize the technique, the effects of various parameters, such as sample volume, sample headspace volume, sample heating temperature and extraction time were studied on the extraction efficiency as previously reported (24).

GC-MS analysis

A Varian 3800 gas chromatograph directly interfaced with a Varian 2000 ion trap mass spectrometer (VarianSpa, Milan, Italy) was used with injector temperature, 260°C; injection mode, splitless; column, 60 m, CP-Wax 52 CB 0.25 mm i.d., 0.25 μm film thickness (ChrompackItalys.r.l., Milan, Italy). The oven temperature was programmed as follows: 45°C held for 5 min, then increased to 80°C at a rate of 10°C/min, and to 240°C at 2°C/min. The carrier gas was helium, used at a constant pressure of 10 psi; the transfer line temperature, 250°C; the ionization mode, electron impact (EI); acquisition range, 40 to 200 m/z; scan rate, 1 us⁻¹. The compounds were identified using the NIST (National Institute of Standards and Technology) library (NIST/WILEY/EPA/NIH), mass spectral library and verified by the retention indices which were calculated as described by Van den Dool and Kratz (25). The relative amounts were calculated on the basis of peak-area ratios. The dendograms and map of collected samples are seen in Figure 1,2 and identified constituents, major compounds of ten taxa *H. scabrum* calli and collect informations of studied *H. scabrum* populations are listed in Table 1.



Figure 1. Collection sites of the studied *Hypericum scabrum* populations from Turkey

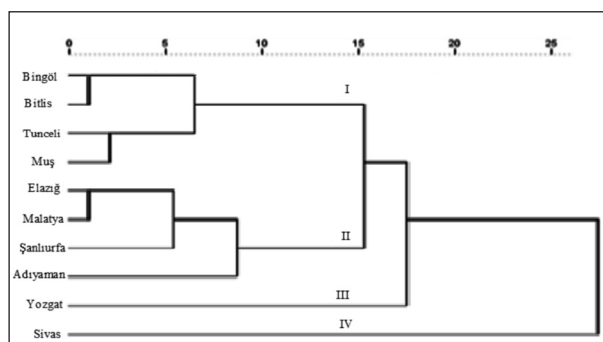

Figure 2. Average-linkage dendrogram of the ten *Hypericum scabrum* populations resulting from the cluster analysis of the calli essential oil components. Chemotype I (Limonene / Germacrene D), Chemotype II (α -pinene), Chemotype III (β -ocimene) and Chemotype IV (β -pinene / α -pinene).

Statistical analysis

The statistical software Cropstat (IRRI 2005) was used to perform the ANOVA and pattern analysis. Standard analyses of variance (anova) were used to analyze the data obtained.

Results

According to the HS-SPME/GC-MS analyses, a total of forty-one components were detected in the examined oils, accounting for 88.70-91.62% of the total compositions (Table 1). A great variability was found in the qualitative composition of the examined oils, since only six components, α -thujene, α -pinene, β -pinene, limonene, germacrene D, spathulenol, were

Table 1. The percentage calli essential oils composition of *Hypericum scabrum* growing in Turkey (%)

Compounds	Bitlis	Muş	Bingöl	Tunceli	Malatya	Elazığ	Şanlıurfa	Adıyaman	Yozgat	Sivas
α -Thujene	0.21	0.32	0.42	0.95	0.32	0.85	0.60	0.60	1.23	1.35
Nonane	1.05	-	0.12	-	2.57	4.05	2.95	3.75	4.45	-
α -pinene	7.68	15.50	12.40	10.45	33.80	33.25	40.20	38.40	8.85	25.20
Camphene	-	0.62	-	-	0.30	0.75	0.42	0.30	-	-
β -pinene	1.30	4.45	2.32	4.80	12.60	12.75	14.63	16.25	5.20	35.74
β -myrcene	0.07	-	-	0.45	-	0.63	-	0.15	0.05	0.04
α -Phellandrene	1.05	0.25	0.07	0.30	0.14	-	0.05	-	0.03	0.55
β -phellandrene	0.42	0.30	0.03	0.20	2.05	-	0.02	0.24	3.22	0.12
α -terpinolene	0.02	-	0.25	0.15	0.12	0.32	0.05	0.15	-	2.00
p-cymene	0.15	-	-	0.32	1.05	0.62	4.42	-	1.15	0.25
α -cubebene	-	0.35	0.23	-	-	0.42	-	0.15	0.14	-
Copaene	0.35	0.20	1.60	0.40	0.65	2.35	3.20	-	-	0.45
Bicyclolemene	-	0.20	0.10	-	-	-	0.04	0.12	0.05	-
Benzene, 1-methyl-4	0.40	-	-	0.25	0.15	0.03	-	-	-	0.05
Limonene	29.50	30.32	28.15	32.21	4.06	2.32	1.14	0.02	1.10	0.54
β -ocimene	-	0.14	-	0.20	-	-	5.16	8.12	37.90	2.00
β -Caryophyllene	3.30	5.00	0.52	0.12	4.15	0.30	0.04	-	1.14	0.21
γ -cadinene	2.50	0.26	0.40	0.34	6.23	8.50	-	10.14	1.24	2.04
Bornylacetate	0.05	-	-	-	0.15	-	0.42	-	0.10	-
3-cyclohexen-1-ol	-	0.04	0.05	0.25	-	-	-	-	-	7.04
δ -cadinene	3.42	-	-	0.30	0.52	1.05	1.01	0.54	0.05	-
α -amorphene	-	0.12	-	-	-	-	0.05	0.12	-	-

(Continued...)

Table 1. The percentage calli essential oils composition of *Hypericum scabrum* growing in Turkey (%) (Continued...)

Compounds	Bitlis	Muş	Bingöl	Tunceli	Malatya	Elazığ	Şanlıurfa	Adıyaman	Yozgat	Sivas
Germaene D	28.25	27.45	30.55	28.42	4.85	6.45	8.56	2.01	0.22	0.15
β -selinene	0.32	-	0.12	0.15	-	0.41	-	0.12	0.25	-
α -terpineol	-	0.02	-	-	0.05	-	0.15	-	-	0.21
Bicyclogermacrene	0.04	-	0.05	0.20	-	0.21	0.20	-	0.12	-
Borneol	-	0.42	0.05	-	-	-	-	0.15	0.20	0.24
Terpin 4 ol	0.02	-	0.04	0.15	-	-	0.05	-	-	-
Pulegone	-	-	-	0.02	0.12	-	-	0.05	-	0.01
Thymol	-	0.05	-	-	-	0.05	0.12	-	0.12	-
Carvacrol	0.30	-	1.50	0.40	0.25	2.25	0.10	0.14	3.45	0.40
β -Elemene	-	0.40	-	0.30	-	0.20	-	1.15	0.05	0.40
Aromadendrene	0.20	-	0.40	-	-	0.02	-	-	-	-
α -Humulene	4.48	0.12	4.15	0.04	0.13	-	5.15	0.05	10.10	0.15
Naphthalene	-	0.10	0.21	-	1.10	1.15	0.02	0.14	-	-
Caryophyllenecoxide	0.12	-	-	0.10	0.24	-	0.03	-	2.10	-
Spathulenol	3.15	0.05	2.12	1.05	4.55	3.28	2.34	5.54	2.20	1.45
Isospathulenol	-	0.12	-	-	0.32	0.47	0.25	-	-	-
α -cadinol	-	0.52	0.12	-	-	0.95	-	0.15	0.05	0.10
β -Eudesmol	0.40	-	-	0.30	0.12	-	0.25	-	-	-
Phytol	-	0.70	0.25	-	-	0.20	-	0.15	0.12	0.30
Monoterpenes	40.70	50.49	46.09	50.45	55.84	45.87	67.08	64.56	61.40	64.61
Sesquiterpenes	43.53	34.79	38.24	31.72	21.76	24.61	19.12	20.09	17.71	21.95
Others	5.39	3.74	5.92	8.65	12.99	19.35	5.42	4.05	5.92	4.55
Total	89.62	89.02	90.25	90.82	90.59	89.83	91.62	88.70	85.03	91.11

in common among all populations of *H. scabrum* calli analyzed. Moreover, the mentioned components showed a relatively high variation in levels. α -pinene (7.68-40.20%), β -pinene (1.30-35.74%), limonene (0.02-32.21%) and germacrene D (0.15%-30.55%) were found as the most abundant compounds (Table 1). This different behavior could be ascribed to the juvenile phase maintained in *in vitro* conditions (26) or to the artificial growing in an *in vitro* environment.

Discussion

The highest amounts of these constituents were found in the oils from şanlıurfa, Sivas, Tunceli and Bingöl populations, respectively. The calli of *H. scabrum* speci-

mens of ten populations from different region of Turkey were found to contain between 30 and 35 compounds in their essential oils, making up between 84 and 90% of the total compounds present (Table 1). β -ocimene (35.74%), α -humulene (10.10%), α -pinene (8.85%) in Yozgat population; Limonene (28.15%), germacrene D (30.55%), α -pinene (12.40%) in Bingöl population; α -pinene (33.25%), β -pinene (12.75%), γ -cadinene (8.50%) in Elazığ population; α -pinene (33.80%), β -pinene (12.60%), γ -cadinene (6.23%) in Malatya population; β -pinene (35.74%), α -pinene (25.20%), γ -cadinene (7.04%) in Sivas population; Limonene (32.21%), germacrene D (28.42%), α -pinene (10.45%) in Tunceli population; α -pinene (40.20%), germacrene D (8.56%), β -ocimene (5.16%) in şanlıurfa population; α -pinene (38.40%), β -pinene (16.25%), β -ocimene

Table 2. Origins and geographical characteristics of studied *H. scabrum* populations

Number	Area of sampling collection	Populations	Altitude (m)	Collection Time	Habitat	Voucher number
1	Yozgat: Akdağ Madeni, Davutlu village	Davutlu village	1150-1250	18.06.2014	Steppe, rocky and stony place, opening of Quercus foresty	5424
2	Bingöl: Vicinity of Dikme village	Dikme village	1650-1700	18.06.2013	Rocky areas	5286
3	Elazığ: Keban	Aslankaşı village	1300-1400	25.06.2013	Rocky slopes	5327
4	Malatya: Sürgü region	Sürgü region	1300-1350	05.07.2015	Road edges	5689
5	Sivas: Zara region	Halkalı and Korkut villages	1400-1500	19.06.2014	Steppe, gypsum areas, hill, slope, rocky and stony place opening of foresty	5426
6	Tunceli: Ovacık, Munzur-Yılanlı mountain	Munzur-Yılanlı mountain	1800-2000	12.06.2015	Rocky and stony place	5684
7	Şanlıurfa: Between Siverek to Şanlıurfa	Between Siverek to anlıurfa, 20. km	600-700	07.06.2014	Road edge, rocky areas	5415
8	Adıyaman: Between Turuş village and Atatürk	Between Turuş village and Atatürk Dam	600-700	08.06.2014	Rocky-steppe areas	5417
9	Bitlis: Tatvan	Suboyu village	1650-1750	27.06.2015	Rocky and stony slopes	5687
10	Muş: Muş-Bingöl 10. km	Muş-Bingöl 10. km	1300-1350	28.06.2015	Roadside, steppe	5688

(8.12%) in Adıyaman population; Limonene (29.50%), germacrene D (28.25%), α -pinene (7.68%) in Bitlis population; Limonene (30.32%), germacrene D (27.45%), α -pinene (15.50%) in Muş population; were determined major compounds (Table 1).

The identification of particular chemotypes of *H. scabrum* calli in this study, displaying a dominant production of α - and β -pinene, limonene, germacrene D, β -ocimene has led to the development of a hypothesis that particular populations (or chemotypes) of this species calli are rich in α -/ β -pinene (e.g. monoterpene hydrocarbons), but not produce both groups of compounds in higher amounts simultaneously (Table 1). This study evidences that *in vitro* conditions influenced the quali quantitative compositions of the calli essential oils of *H. scabrum* in comparison with the *in vivo* grown mother plants.

α -pinene was determined in the cali essential oils of all investigated populationits proportion ranging from 8 to 40% (Tab. 1). This compound had previously also been identified as a major component of

the essentials oils of *H. scabrum* (40.9%) from Alamut Mountain (27). Regarding the qualitative pattern of the essential oils of some *Hypericum* species, there are similar results for α -pinene, major/high component reported (28, 29). Nevertheless a large differences occurred in the amounts of some compounds. It is noteworthy that in the composition of Sivas population β -pinene (35.74%) was determined more than other populations; this compound showed different chemical behavior from all the other studied populations, (Table 1). α -Pinene (37.20%) and β -Pinene (12.77%) were found as the major components in the essential oil of *H. scabrum* from Turkey as well (30). β -ocimene was absent from the essential oil of Bitlis, Bingöl, Malatya, Elazığ populations or present only in low percentages in the calli essential oil of Muş (0.14%), Tunceli (0.20%), Sivas (2.00%) populations, but it is noteworthy that β -ocimene (35.74%), was the major component only in Yozgat population (Table 1). The calli essential oils of Bitlis, Muş, Bingöl, Tunceli populations had a chemical composition different from that of

Table 3. The main compounds of studied calli *H. scabrum* populations

Population name	Major compounds (content [%]a)
Yozgat: Akdağ Madeni, Davutlu village	β -ocimene (37.90), α -humulene (10.10), α -pinene (8.85), β -pinene (5.25), nonane (4.45)
Bingöl: Vicinity of Dikme village	Limonene (31.15), germacrene D (30.55), α -pinene (12.40), α -humulene (4.15)
Elazığ: Keban, Aslankaşı village	α -pinene (36.25), β -pinene (15.75), γ -cadinene (8.50), germacrene D (6.45), nonane (4.05)
Malatya: Sürgü region	α -pinene (38.80), β -pinene (15.60), γ -cadinene (6.23), limonene (6.06), β -caryophyllene (4.15)
Sivas: Zara region, Halkalı and Korkut villages	β -pinene (37.74), α -pinene (32.20), γ -cadinene (7.04)
Tunceli: Ovacık, Munzur-Yılanlı mountain	Limonene (32.21), germacrene D (28.42), α -pinene (18.45), β -pinene (4.80)
Şanlıurfa: Between Siverek to Şanlıurfa, 20. km	α -pinene (40.20), germacrene D (6.56), β -ocimene (5.16), α -humulene (5.15), p-cymene (4.42)
Adıyaman: Between Turuş village and Atatürk Dam	α -pinene (38.40), β -pinene (16.25), β -ocimene (8.12), spathulenol (5.54)
Bitlis: Tatvan, Suboyu village	Limonene (29.50), germacrene D (25.25), α -pinene (10.68), α -humulene (4.48)
Muş: Muş-Bingöl 10. km	Limonene (35.32), germacrene D (27.45), α -pinene (15.50), β -pinene (4.45)

a) All compounds with a content >4% of the total oil composition were considered as major compounds; their contents in % are given in parentheses.

all the other species, producing high amounts of limonene (29.50%, 30.32%, 28.15%, 32.21%, respectively), and germacrene D (28.25%, 27.45%, 30.55%, 28.42%, respectively); whereas these compounds were not detected as major component in some studied populations or absent (Table 1). Germacrene D is also detected as main compounds of *H. perforatum* growing wild in Tajikistan (31). In addition twenty-six components were identified in the oil of *H. scabrum* with α -pinene (44.8%) and spathulenol (7.1%), as the most abundant components (31); α -pinene is also as the most abundant component of all studied populations calli, whereas spathulenol were detected low percentages almost all studied populations (Table 1). Germacrene D was one of the major constituents of the calli essential oils of Bingöl population (30.55%) (Table 1). In the calli essential oil of Adiyaman-Yozgat and Sivas populations Germacrene D was determined in low percentages (Table 1); this compound was also main constituents of *H. perforatum* essential oil (32).

In this research thymol, a rare compound in plant essential oil, or was not found in all *H. scabrum* populations calli. The same result has been previously reported by Mohammed Reza *et al.*, (33) in *H. perforatum* populations growing in Iran. In agreement to our results, α -pinene was also previously reported as a major component essential oil of *H. capitatum* var. *capitatum* from Turkey (34). Contrarily, constituents such as germacrene D, limonene (35), γ -muurolene (36) and carvacrol (37), which have been previously reported as main components essential oils of some *Hypericum* taxa, were not detected at all in the investigated calli samples in our research. All populations calli essential oils were characterized by a high content of monoterpenes (54.7%). The calli essential oil analysis showed that monoterpene concentrations were higher than those of sesquiterpenes. Whereas essential oil composition of five *Hypericum* species from southern Brazil showed that sesquiterpenes are present in higher concentrations (38). Among the monoterpene major components, α -pinene and β -pinene determined in the calli essential oils of both our studied populations were reported in the essential oils of *H. myrianthum* (6.5%, 3.7%) (38), *H. perfoliatum* (64.3%, 3.2%), *H. linarifolium* (31.2%, 11.0%) and *H. pulchrum* (46.8%, 12.5%) (28). Essential oils *in vitro* cultured

plants was predominantly composed of hydrogenated and oxygenated monoterpenes in comparison of *in vitro* plant materials, in respect to the propagated one, could be the consequence of the different ontological stage. This hypothesis is supported by the fact that *in vitro* cultured plants are considered, by definition, at juvenile stage and it is well known that accumulation of the highest capacity of biosynthesis (39, 40) It's remarkable that the essential oils profile of the *in vivo* sample does not correspond with that reported in the literature (41, 42)

An interesting fact is that, although studied *H. scabrum* populations are some quantitative and qualitative different in their essential oil compositions. In planta, culture conditions are crucial factor for growth and development directly affecting the photosynthetic rate and influence the qualitative composition of *in vitro*. These similarities or differences may be dependent from local, climatic, seasonal factors and regulated by plant growth regulators during *in vitro* cultures. All species growing in close habitats and near locations. Further investigations of the essential oil compositions of larger number of relative and distant populations of different and close taxa, along with more data about *Hypericum* taxa, could be helpful in chemotaxonomy.

Nevertheless the populations growing in eastern Iran, including Bitlis, Muş, Bingöl and Tunceli populations, showing different temperature and altitudes, constituted a same group (Chemotype I; Fig. 1). It has already been explained that the distribution of calli essential oil chemotypes seemed to be linked with the local selective forces acting on the chemotype variety. In fact, moisture, temperature, topography, and edaphic factors and/or fauna and flora acts on terpene-biosynthesis pathways and contribute to the emergence of different chemical oil profiles (43). The first chemotype (I) was characterized by high content of limonene (28.15%-32.21%) and germacrene D (27.45%-30.55%); α -pinene (7.68%) was other main component of this chemotype. Chemotype II was composed of four populations (Malatya, Elazığ, şanlıurfa and Adiyaman) characterized by high content of α -pinene (33.80% - 33.25% - 40.20% - 38.40%, respectively); α -pinene chemotype was also recorded in southeastern France. Chemotype III was composed of one population (Yozgat) with β -ocimene (37.90%) as

the major compound. The lower amount of monoterpenoids such as α -pinene and β -pinene in this population made it a separate chemotype. This chemotype contained the lowest amount of sesquiterpene hydrocarbons (17.71%) compared to the other chemotypes (19.12% - 43.53%). The high content of β -pinene (35.74%) and α -pinene (25.20%) differentiated the population from Sivas as a distinct chemotype (chemotype IV: β -pinene/ α -pinene). The calli essential oil variation observed among *H. scabrum* populations in accordance with their geographical and bioclimatic distribution imposes that conservation strategies should be made appropriately, taking into account these factors; conservation strategies should concern all populations representing the different chemotypes (44).

In vitro technology is well recognized for biodiversity preservation and may represents an alternative method to satisfy the increasing demand for both volatile (e.g. essential oils) and non volatile bioactive secondary metabolites. Moreover, since the products of secondary metabolism have always been considered as plant responses to biotic and abiotic stress, several physical and chemical elicitors, can be applied to stimulate plants to produce high concentrations of a desired compound or group of compounds.

In conclusion, aroma and biological activities of essential oils is determined by the type of compounds present and their relative percentages, such variability in the calli essential oil profile of studied populations enabled selection of those with specific aromas or activities of their calli essential oils for use in relevant industries and sectors. In addition the chemical results from this study might be helpful chemotaxonomy and potential usefulness of *Hypericum* taxa. Besides, due to their various bioactivities, further researchs should be carried out on the drug development of *Hypericum* extracts and their constituents.

References

1. Robson NKB. Studies in the genus *Hypericum* L. (Guttiferae). Bulletin of the British Museum-Natural History, Botany. 2001; 8: 55-226.
2. Tuzlaci E, Aymaz PE. Turkish folk medicinal plants, Part IV: Gönen. Fitoterapia. 2001; 72: 323-343.
3. Sezik E, Yesilada E, Honda G, Takaishi Y, Takeda Y. Traditional medicine in Turkey X. Folk medicine in Central Anatolia. Journal of Ethnopharmacology. 2001; 75: 95-115.
4. Kültür S. Medicinal plants used in Kirklareli Province (Turkey). Journal of Ethnopharmacology. 2007; 111: 341-364.
5. Blumenthal M, Goldberg A, Brinckmann J. Integrative Medicine Communications. Herbal Medicine. 2000; 359-366.
6. Hosni K, Msaada K, Taarit MB, Ouchikha O, Kallel M, Marzouk B. Essential oil composition of *Hypericum perforatum* L. and *Hypericum tomentosum* L. growing wild in Tunisia. Industrial Crops Product. 2008; 27: 308-314.
7. Hasanein P, Shahidi S. Effects of *Hypericum perforatum* extract on diabetes induced learning and memory impairment in rats. Phytotherapy Research. 2011; 25: 544-549.
8. Hernandez MF, Fale PL, Araújo MEM, Serralheiro MLM. Acetylcholinesterase inhibition and antioxidant activity of the water extracts of several *Hypericum* species. Food Chemistry. 2010; 120: 1076-1082.
9. Santar IP, Akkol EK, Yilmazer D, Baykal T. Kırmızıbekermez, H, Alper M, Yesilada E, Investigations on the *in vivo* wound healing potential of *Hypericum perforatum* L. Journal of Ethnopharmacology. 2010; 127: 468-477.
10. Ciccarelli D, Andreucci A, CandPagni AM. Translucent glands and secretory canals in *Hypericum perforatum* L. (Hypericaceae): morphological, anatomical and histochemical studies during the course of ontogenesis. Ann. Botany. 2001; 88: 637-44.
11. Council of Europe. European Pharmacopoeia. 4th edition. Strasbourg, France: 2001.
12. American Botanical Council. St. John's wort. In: Blumenthal, M.; Goldberg, A., editors. The complete German Commission E monographs: Therapeutic guide to herbal medicines. Austin, Texas: 1998. 214-215.
13. Miraldi E, Biagi M, Giachetti D. Chemical constituents and effects of topical application of Oleum Hyperici on skin sensitivity to simulated sun exposure. Natural Product Communication. 2006; 1: 209-213.
14. Zdunić G, Gođevac D, Milenković M, Vučelčević D, Šavikin K, Menković N, Petrović S. Evaluation of *Hypericum perforatum* oil extracts for an anti-inflammatory and gastroprotective activity in rats. Phytotherapy Research. 2009; 23: 1559-1564.
15. Kızıl G, Toker Z, Ozen HC, Aytakin C. The antimicrobial activity of essential oils of *Hypericum scabrum*, *Hypericum scabroides* and *Hypericum triquetrifolium*. Phytotherapy Research. 2004; 18: 339-341.
16. Ceakir A, Duru ME, Harmandar M, Ciriminna R, Passananti S, Piozzi F. Comparison of the volatile oils of *Hypericum scabrum* L. and *Hypericum perforatum* L. from Turkey. Flavour Fragrance Journal. 1997; 12: 285-287.
17. Decosterd AL, Hoffman E, Kyburz R. A new phloroglucinol derivative from *Hypericum calycinum* with antifungal and *in vitro* antimalarial activity. Planta Medicine. 1991; 57: 548-551.
18. Erdogruel Ö, Azırak S, Tosalı C. Antimicrobial activities of *Hypericum scabrum* L. extracts. Ksuj Science. 2004; 7: 38-42.
19. Unal EL, Mavı A, Aydan Kara A, Cakır A, engul MS,

- Yıldırım A. Antimicrobial and antioxidant activities of some plants used as remedies in Turkish traditional medicine. *Pharma Biology*. 2008; 46: 207-224.
20. Eslami B, Nabavi SF, Nabavi MA, Ebrahimzadeh Mahmood M. Pharmacological activities of *Hypericum scabrum* L. *European Review for Medicine and Pharmacology Science*. 2011; 15: 532-537
 21. Baser KHC, Ozek T, Nuriddinov HR, Demirci AB. Essential oils two *Hypericum* species from Uzbekistan. *Chemistry of Natural Compound*. 2002; 38: 54-57.
 22. Davis PH. *Flora of Turkey and the East Aegean Islands*. Edinburgh: Press. 1967; 2: 355-401.
 23. Murashige T, Skoog F. A revised medium for rapid growth and bioassays with tobacco tissue cultures. *Physiolog Plant*. 1962; 15: 473-494.
 24. Verzera A, Zino M, Condurso C, Romeo V, Zappala M. Solid-phase microextraction and gaschromatography/mass spectrometry for the rapid characterisation of semi-hard cheeses. *Analytic Bioanalytic Chemistry*. 2004; 380: 930-936.
 25. Van Den Dool H, Kratz PD. A generalization of the retention index system including linear temperature programmed gas-liquid partition chromatography. *Journal Chromatography*. 1963; 11: 463-471.
 26. Azam A, Qian J, Zhang B, Xu C, Chen K. Citrus leaf volatiles as affected by developmental stage and genetic type. *International Journal Molecule Science*. 2013; 14: 17744-17766.
 27. Dadkhah A, Fatemi F, Farsani ME, Roshanaei K, Alipour M, Aligolzadeh H. Hepatoprotective effects of Iranian *Hypericum scabrum* essential oils against oxidative stress induced by acetaminophen in rats. *Brazilian Archives Biology Technology*. 2014; 57: 3.
 28. Nogueira T, Marcelo-Curto MJ, Cristina Figueiredo A, Barroso JG, Pedro LG, Rubiolo P, Bicchi C. Chemotaxonomy of *Hypericum* genus from Portugal: geographical distribution and essential oils composition of *Hypericum perforatum*, *Hypericum humifusum*, *Hypericum linarifolium* and *Hypericum pulchrum*. *Biochemical Systematic Ecology*. 2007; 36: 40-50.
 29. Bagci E, Bekci F. Variation in essential oil composition of *Hypericum scabrum* and *H. scabroides* N. Robson & Poulter (Hypericaceae) aerial parts during its phenological cycle. *Acta Botanica Gallica*. 2010; 157: 247-254.
 30. Bagci E, Yüce E. Essential Oils of the Aerial Parts of *Hypericum apricum* Kar. and Kir. and *Hypericum davisii* Robson (Guttiferae) Species from Turkey. *Asian Journal of Chemistry*. 2010; 22: 7405-7409.
 31. Farukh S, Sharopov I, Gulmurodov S, Setzer N. Essential oil composition of *Hypericum perforatum* L. and *Hypericum scabrum* L. growing wild in Tajikistan. *Journal Chemistry Pharmacology Research*. 2010; 2: 284-290.
 32. Aleksandra S, Đorđević. Chemical Composition of *Hypericum perforatum* L. Essential oil Advance Technology. 2015; 4: 64-68.
 33. Mohammad Reza M, Ali E, Filippo M, Reza F, Darab Y. Chemical Variation in the Essential Oil Compositions from 1 Iranian Populations of *Hypericum perforatum* L. *Industrial Crops and Product*. 2015; 76, 565-573.
 34. Bagci E, Yuce E. Constituents of the Essential Oils of Two *Hypericum capitatum* Choisy Varieties (var. *capitatum* and var. *luteum* Robson) from Turkey. *Journal of Essential oil Bearing Plant*. 2011a; 14, 106-113.
 35. Bagci E, Yuce E. Composition of the essential oil of *Hypericum salsolifolium* Hand.- Mazz. and *Hypericum retusum* Aucher from Turkey. *Acta Bot. Gallica*. 2011 b; 158: 169-172.
 36. Pavlovic M, Tzakou O, Petrakis PV, Coudalis M. The essential oil of *Hypericum perforatum* L., *Hypericum tetrapterum* Fries and *Hypericum olympicum* L. growing in Greece. *Flavour Fragrance Journal*. 2006; 21: 84-87.
 37. Erken S, Malyer H, Demirci F. Chemical Investigations on Some *Hypericum* Species Growing In Turkey-I. *Chemistry Natural Compound*. 2001; 37: 434-438.
 38. Ferraz ABF, Limberger RP, Bordignon SAL, Von Poser GL, Henriques AT. Essential oil composition of six *Hypericum* species from southern Brazil. *Flavour Fragrance Journal*. 2004; 20: 335-339.
 39. Croteau R, Felton M, Karp F, Kjonas R. Relationship of camphor biosynthesis to leaf development in sage (*Salvia officinalis*). *Plant Physiology*. 1981; 67; 820-824.
 40. Grausgruber-Groger. 2012. Seasonal influence on gene expression of monoterpene synthases in *Salvia officinalis* (Lamiaceae). *Journal Plant Physiology*. 169: 353-359.
 41. Kamatou GPP, Viljoen AM, Figueiredo AC, Tilney PM, Van Zyl RL, Barroso JG, Pedro LG, Van Vuuren SF. Trichomes, essential oil composition and biological activities of *Salvia albicaulis* Benth. and *S. dolomitica* Codd, two species from the Cape region of South Africa. *South African Journal Botany*. 2007; 73: 102-108.
 42. Kamatou GPP, Viljoen AM, Steenkamp P. Antioxidant, anti-inflammatory activities and HPLC analysis of South African *Salvia* species. *Food Chemistry*. 2010; 119: 684-688.
 43. Zouari N, Ayad I, Fakhfakh N, Rebai A, Zouari S. Variation of chemical composition of essential oils in wild populations of *Thymus algeriensis* Boiss. et Reut., a North African endemic Species. *Lipids Health Disease*. 2012; 11: 1-12.
 44. ElHadj A, Zaouali IB, Bejaoui YA, Boussaid M. Variation of the Chemical Composition of Essential Oils in Tunisian Populations of *Thymus algeriensis* Boiss. et Reut. (Lamiaceae) and Implication for Conservation. *Chemical Biodiversity*. 2010; 7; 1276-1289.

Correspondence:

Ömer Kiliç

Department of Park and Garden Plants, Technical Science Vocational College, Bingol University, 12000, Bingol, Turkey
Tel No: +90 0 426 216 00 12 - Fax No: +90 0 426 216 00 22
E-mail: omerkilig77@gmail.com